

# ***ELIPTICAL 6.5***

***Art No. 726 065***

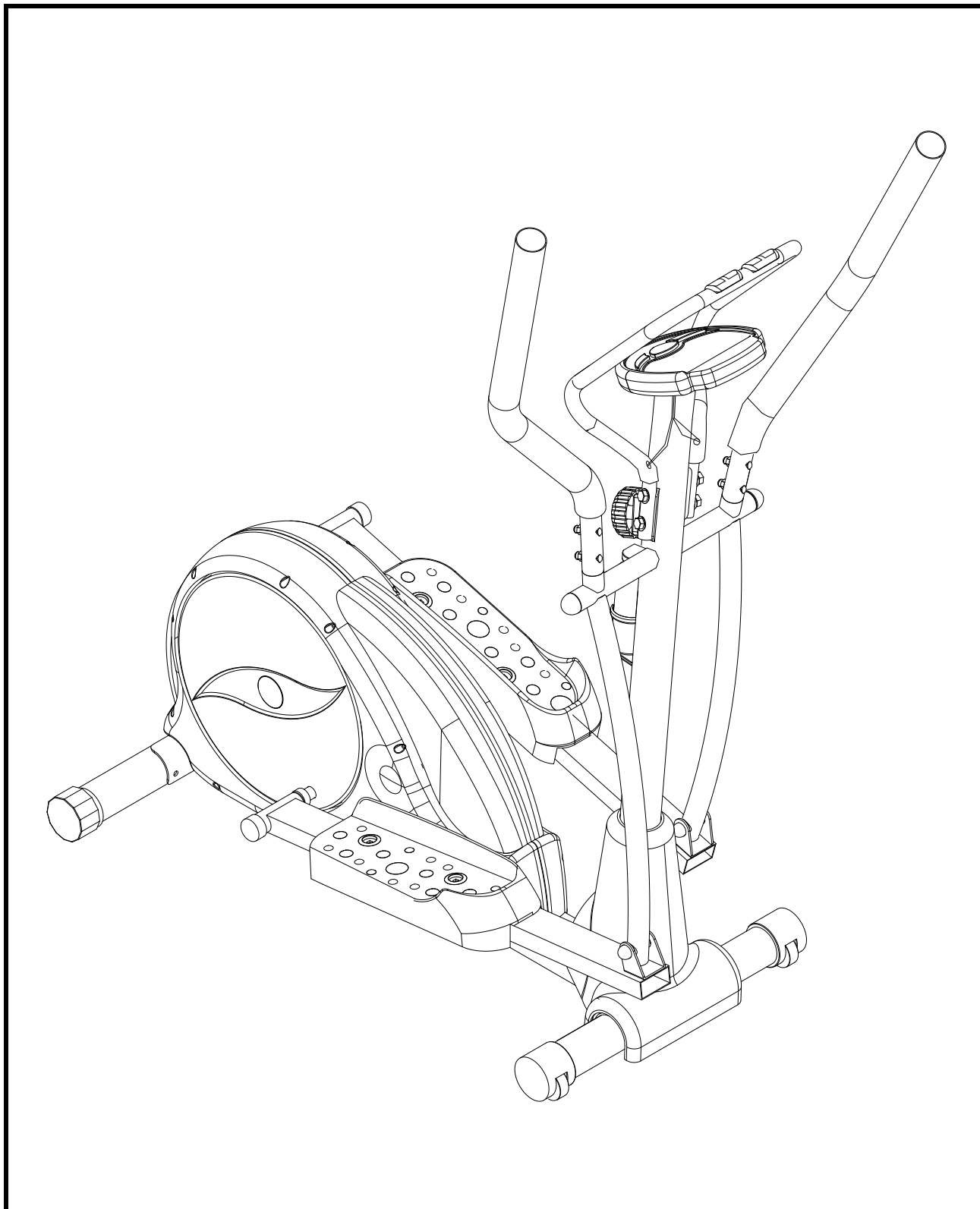

# EXPLODED DRAWING

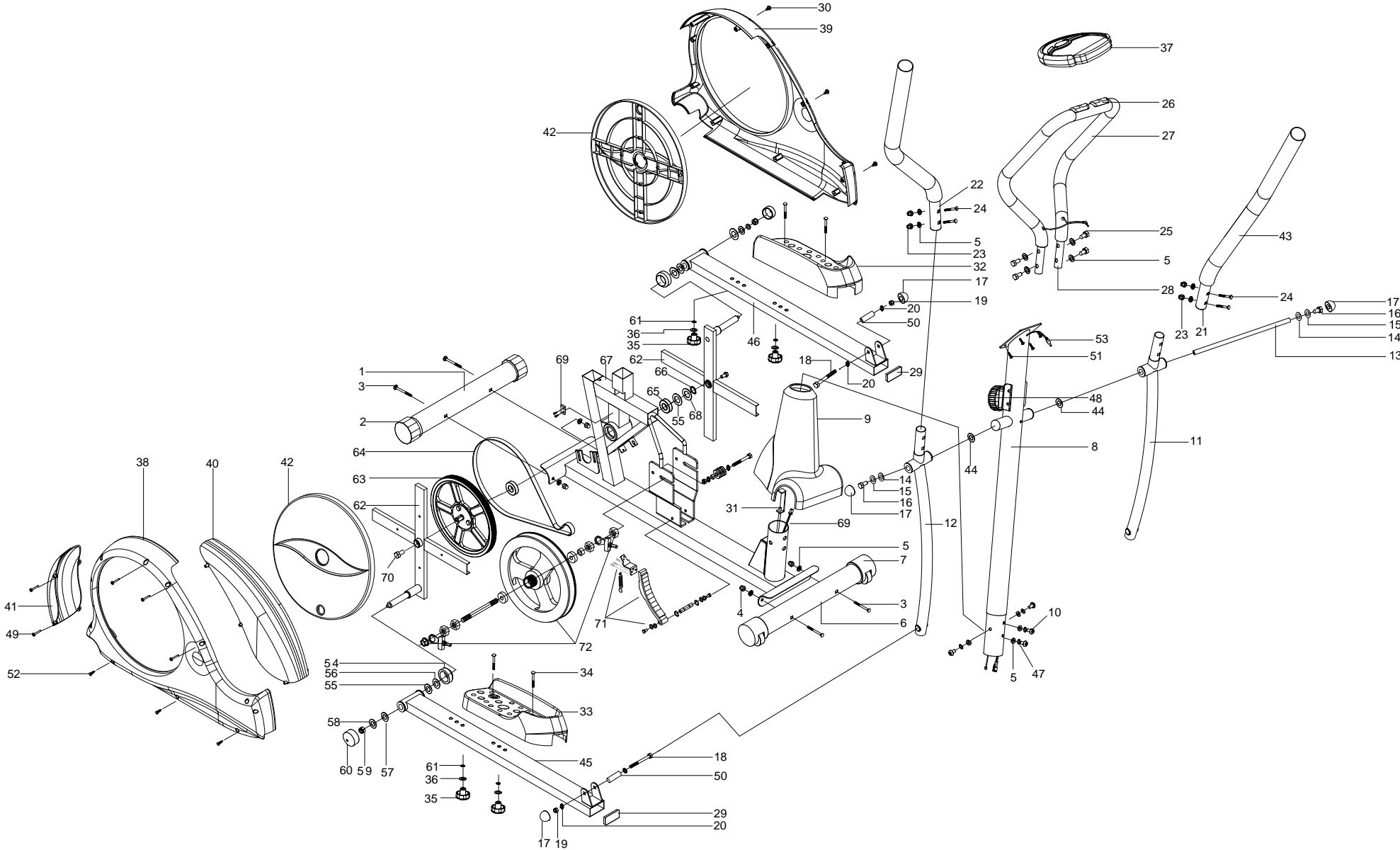

# Parts List

NO	DESCRIPTION	Q'TY	NO	DESCRIPTION	Q'TY
1	REAR STABILIZER	1	38	CHAINCOVER (RIGHT)	1
2	ADJUSTING CAP	2	39	CHAINCOVER (LEFT)	1
3	CARRIAGE BOLT	4	40	COVER FOR FLYWHEEL	1
4	HEX NUT	8	41	COVER	1
5	SEMICIRCLE WASHER	16	42	DISC COVER	2
6	FRONT STABILIZER	1	43	FOAM GRIP	2
7	TRANSPORTATION WHEEL	2	44	WAVE WASHER	5
8	HANDLEBAR POST	1	45	PEDAL ARM (RIGHT)	1
9	COVER FOR HANDLEBAR POST	1	46	PEDAL ARM (LEFT)	1
10	BOLT ALLEN	4	47	SENSOR WIRE (DOWN)	1
11	MOVEABLE HANDLEBAR ( LEFT)	1	48	TENSION CONTROL	1
12	MOVEABLE HANDLEBAR (RIGHT)	1	49	SCREW	4
13	AXLE FOR MOVEABLE HANDLEBAR	1	50	CAP	2
14	WAHER	4	51	CROSS SCREW	4
15	FLAT WASHER	2	52	SCREW	6
16	HEXAGONAL SCREW	4	53	SENSOR WIRE (UPPER)	1
17	SEMICIRCLE CAP	4	54	CAP COR CRANK ARM	2
18	BOLT ALLEN	2	55	WAVE WASHER	5
19	NYLON NUT	3	56	FLAT WASHER	3
20	FLAT WASHER	7	57	WASHER	4
21	HANDLEBAR (LEFT)	1	58	WASHER	4
22	HANDLEBAR (RIGHT)	1	59	NYLON NUT	2
23	NUT	4	60	CAP	2
24	CARRIAGE BOLT	4	61	SPRING WASHER	4
25	BOLT ALLEN	4	62	DIS COVER	2
26	HANDPULSE SET	1	63	PULLEY WHEEL	1
27	FOAM GRIP	1	64	BELT	1
28	FIXED HANDLEBAR	1	65	BEARING	2
29	CAP	2	66	RETAINER RING	1
30	CROSS SCREW	7	67	MAIN FRAME	1
31	SPRING WASHER	1	68	FLAT WASHER	3
32	PEDAL (LEFT)	1	69	RPM SENSOR	1
33	PEDAL (RIGHT)	1	70	HEXAGONAL SCREW	4
34	CARRIAGE BOLT	4	71	MAGNET ARM ASSBY	1
35	FIXING KNOB	4	72	FLYWHEEL SET	1
36	FLAT WASHER	4			
37	COMPUTER	1			

**This exerciser has been designed for home use only. Professional use, commercial or use in gym centers, will automatically cancel the manufacturers' and/or importers' product liability.**

## **Safety Instructions**

Before you start training on your exerciser, please read the instructions carefully. Be sure to keep the instructions for information, in case of repair and for spare part delivery.

- This exerciser is made for home use only and tested up to a max. body weight of 90 kg.
- Follow the steps of the assembly instructions carefully.
- Use only original parts as delivered.
- Before the assembly, be sure to check if delivery is complete by using the included parts-list.
- For assembly use only suitable tools and ask for assistance with assembly if necessary.
- Place the exerciser on an even, non-slippery surface. Because of possible corrosion, the usage of any exerciser in moist areas is not recommended.
- Check before the first training and every 1-2 months that all connecting elements are tight fitting and are in the correct condition.

Replace defective components immediately and/or keep the equipment out of use until repair. For repairs, use only original spare parts.

- In case of repair please ask your dealer for advice
- Avoid the use of aggressive detergents when cleaning.
- Ensure that training starts only after correct assembly and inspection.
- For all adjustable parts be aware of the maximum positions to which they can be adjusted/tightened to.
- This exerciser is designed for adults. Please ensure that children use the exerciser only under the supervision of an adult.
- Ensure that those present are aware of possible hazards, e. g. movable parts during training.

Warning: incorrect/excessive training can cause health injuries.

- Please follow the advice for correct training as detailed in training instructions.
- Users' limit 190 cm.

**Consult your physician before starting with any exercise program me. He can advise on the kind of training and which impact is suitable.**

- The owner's manual is only for customers' reference.
- The supplier can not guarantee for mistakes occurring due to translation or change in technical specification of the product.

**All data displayed are approximate guidance and cannot be used in any medical application**

# Assembly instructions

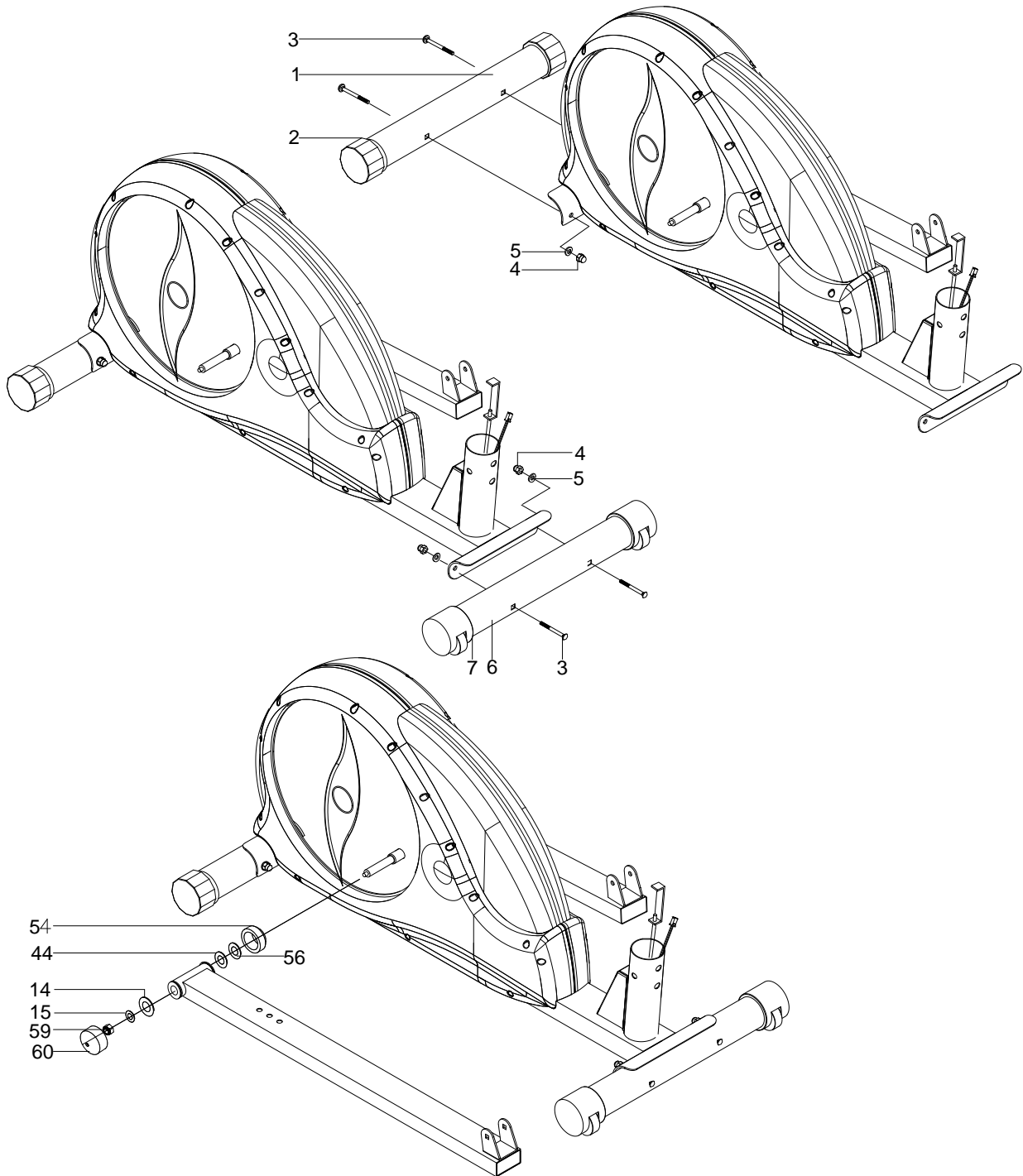

## *Step 1*

Assemble front and rear stabilizers to mainframe using two washers (5),nuts(4) and bolts(3).

Assemble right pedal as shown in the drawing.

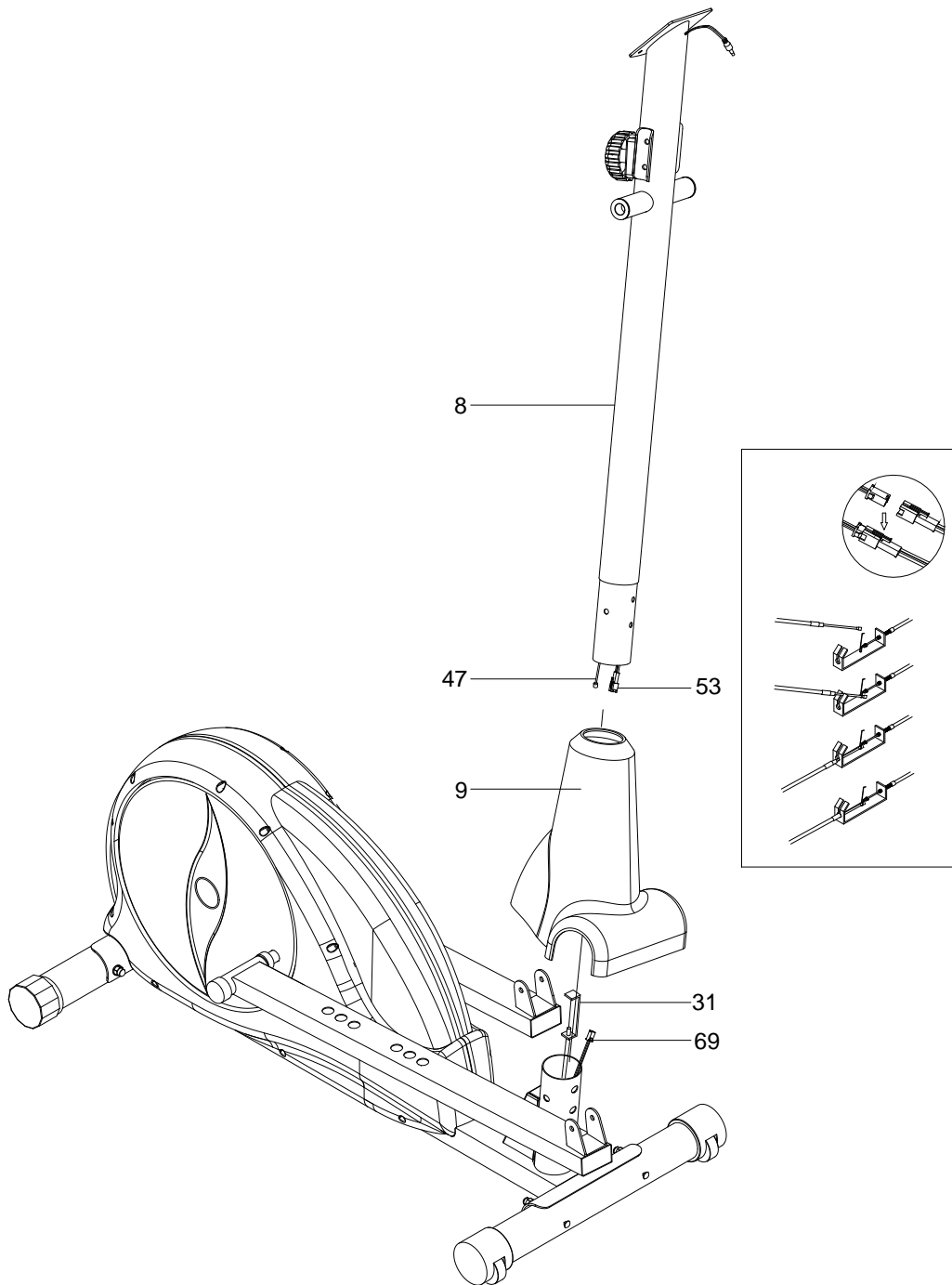

## ***STEP 2***

1. Slide handlebar post (8) through its cover (9).
2. Pull the tension cable out of the handlebar post and please ensure the tension knob is at lightest position (minimum position).
3. Connect the tension cable by pushing the head into the notch of the cable coming from the main frame (see drawing A1-A4). Connect the computer cables (see drawing B).

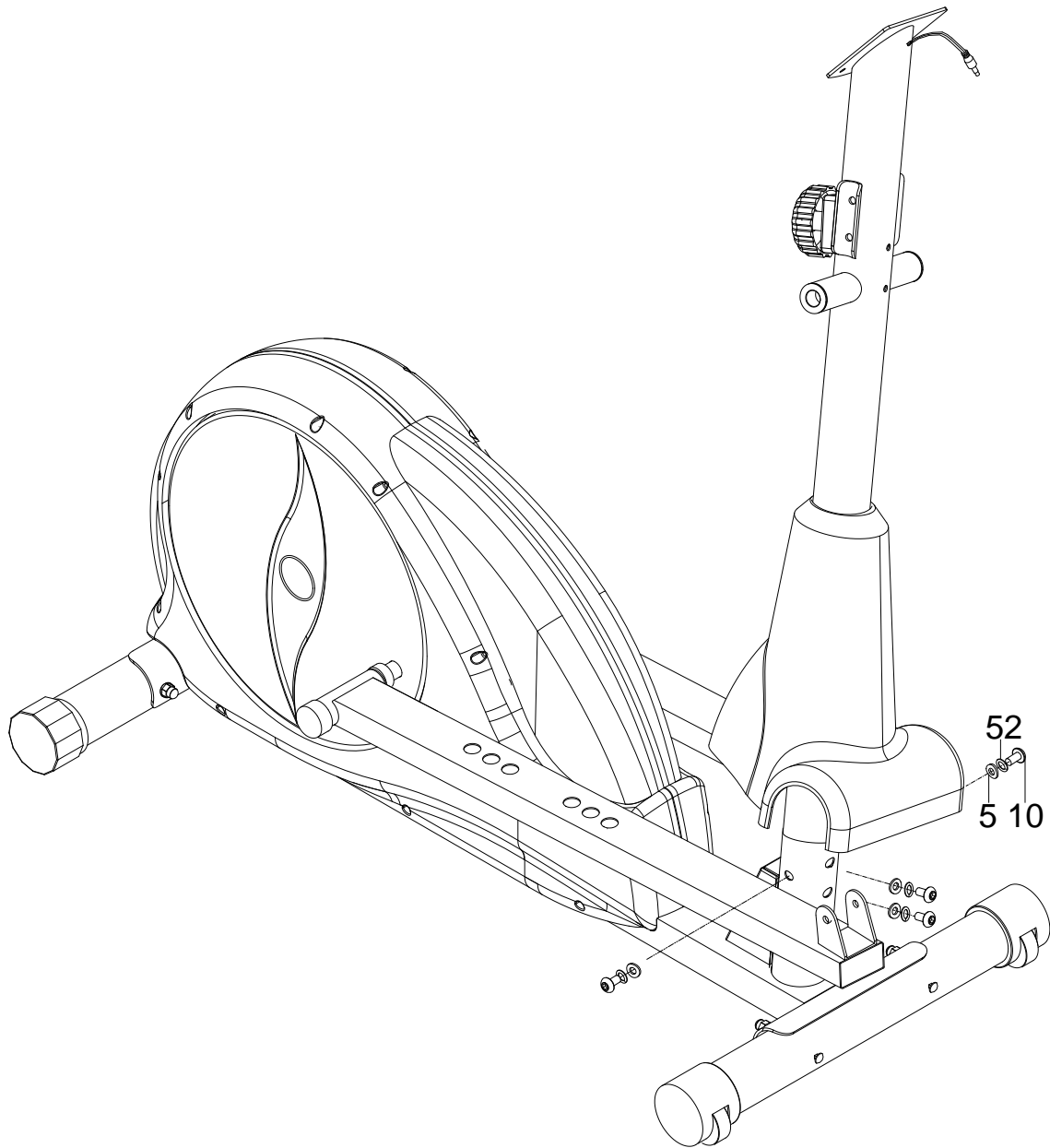

### ***STEP 3***

1. Assemble handlebar post to frame using four washers (5) and bolts (10).
2. Slide down protective cover.

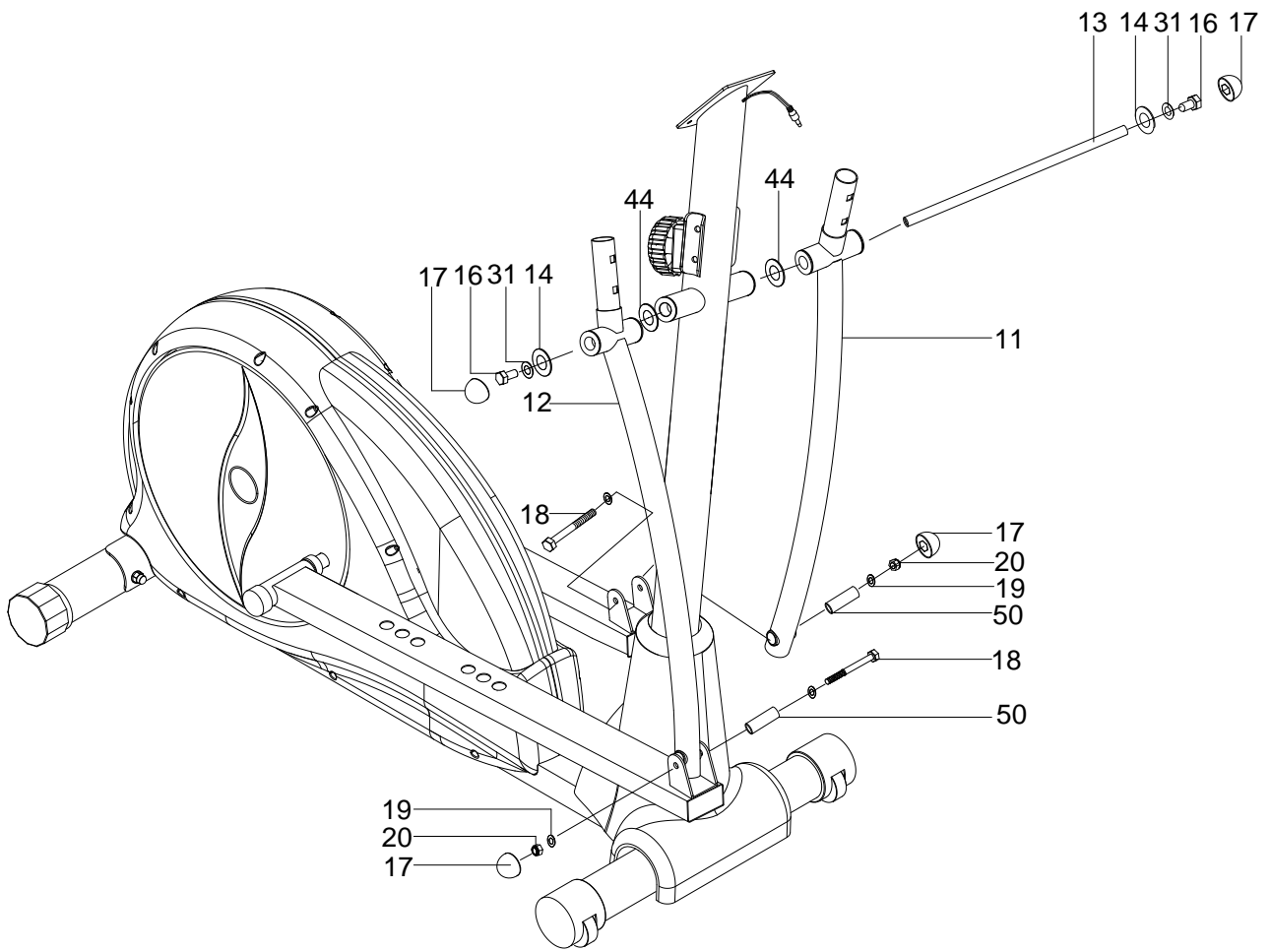

***STEP 4***

1. Position and center axle (13) in the handlebar post.
2. Connect lower handlebars (11&12) this axle using two bushings (44), washers (14) bolt (16), two washers (15) and cover using end caps (17).
3. Connect lower handlebars to pedal supports (45) using four washers (19), bolts (18), two metal bushing(50) and cover using end caps (17).



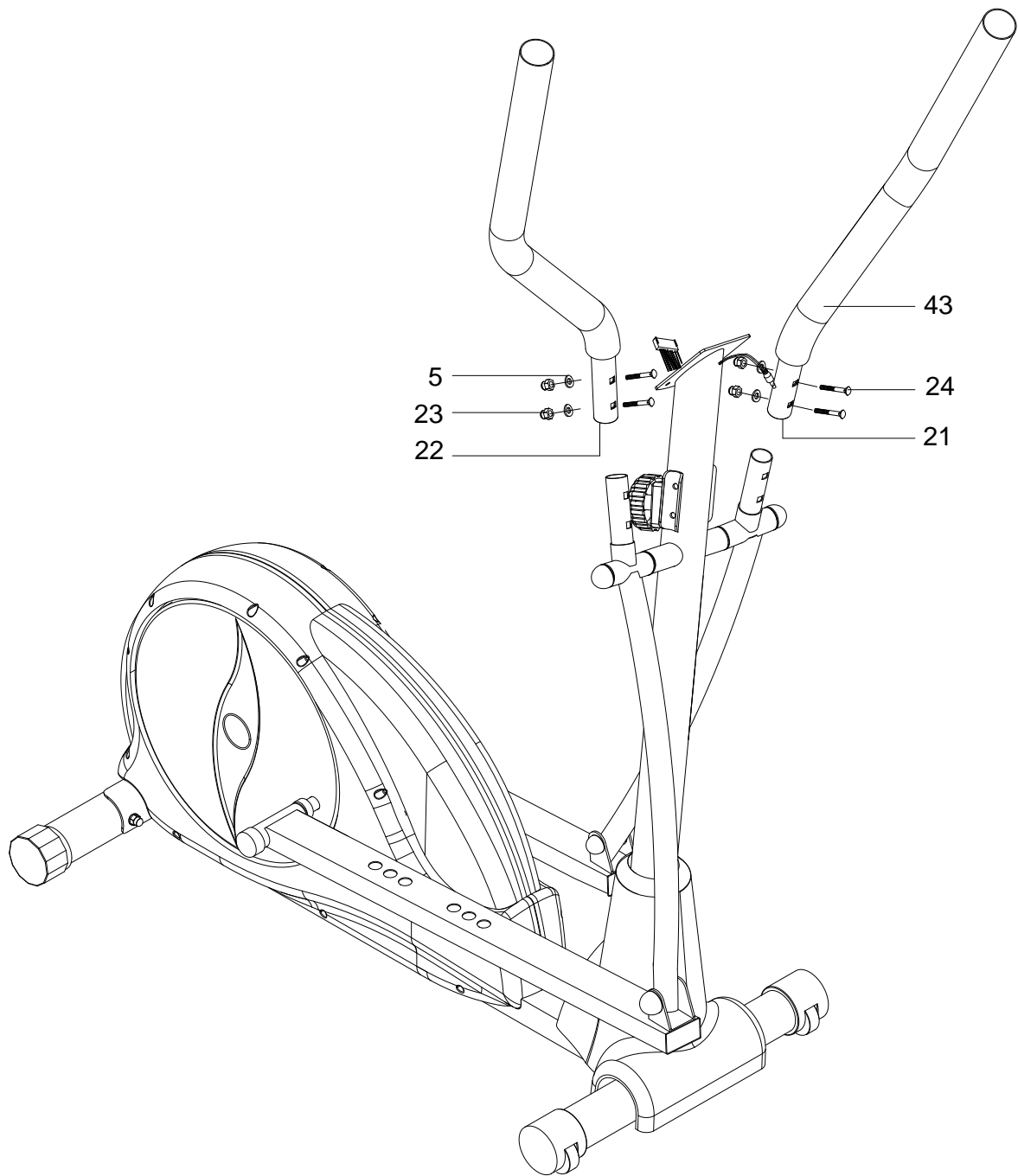

***STEP 5***

Slide in upper handlebars (21&22) and tighten well using four bolts (24) washers (5) and nuts (23).

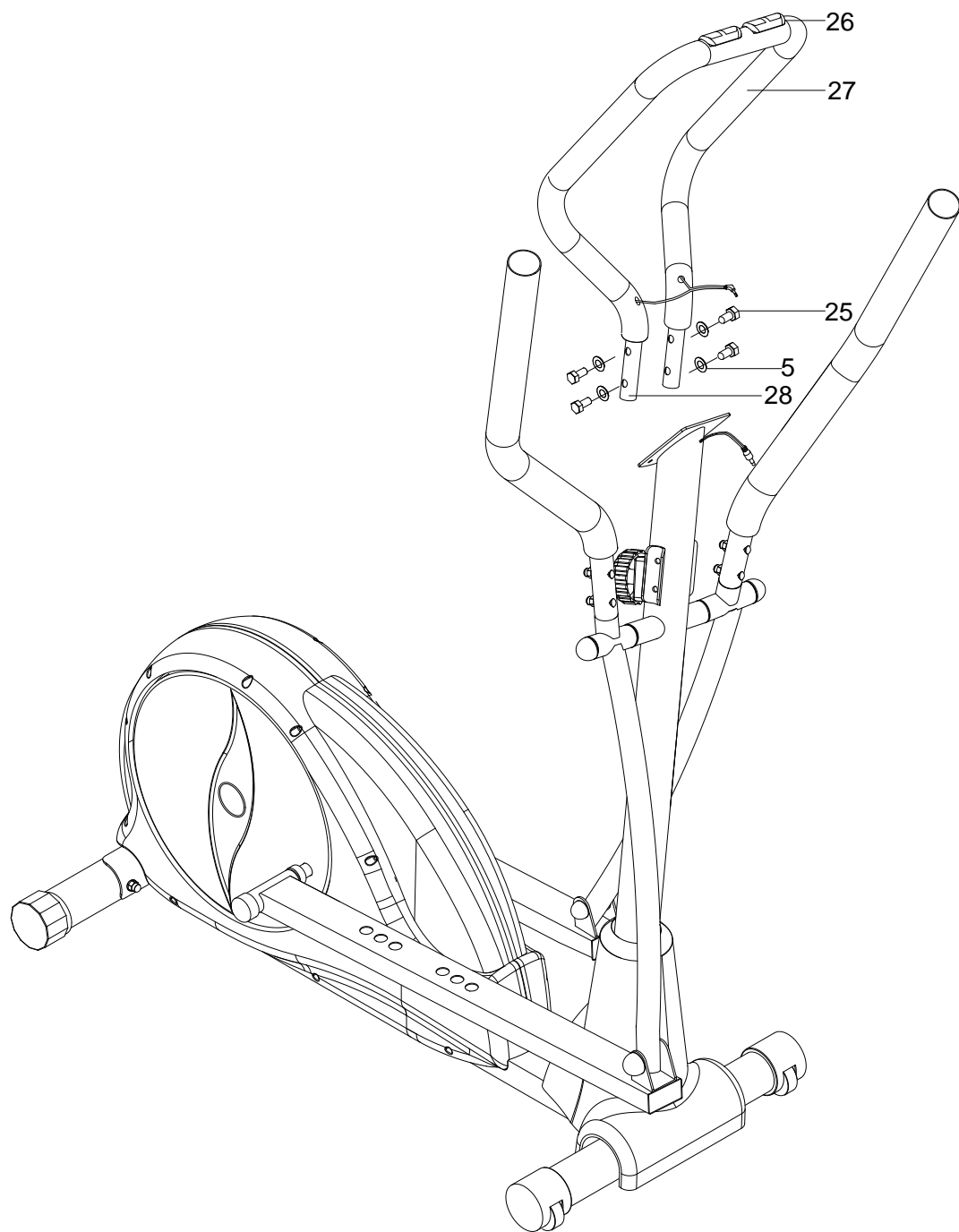

***STEP 6***

Assemble fixed front support (28) using four screws (25) and washers (5).

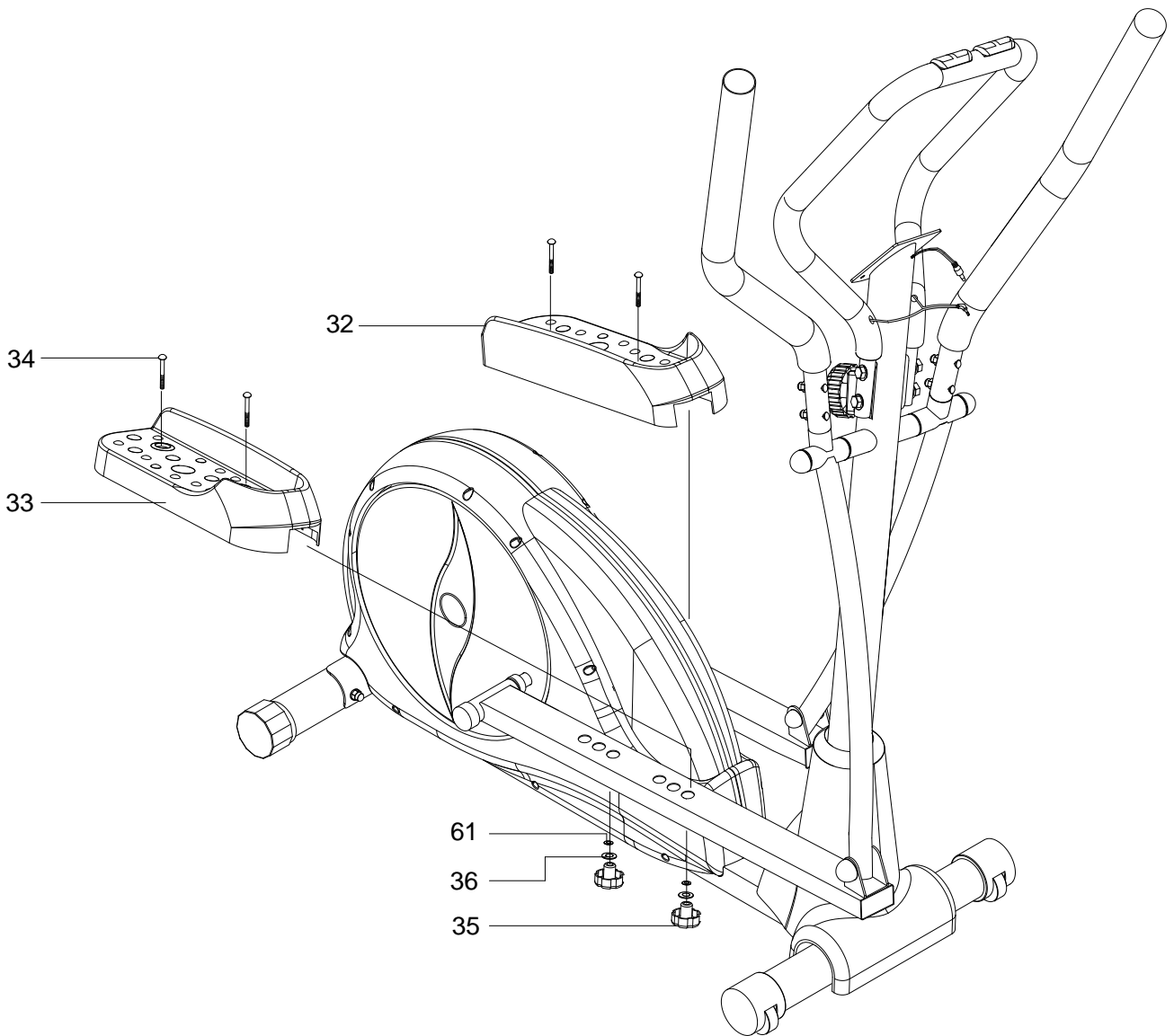

## ***STEP 7***

Assemble pedals (32&33) to their support and fasten using four bolts (34), washers (36) ,spring washers(61) and knobs (35).

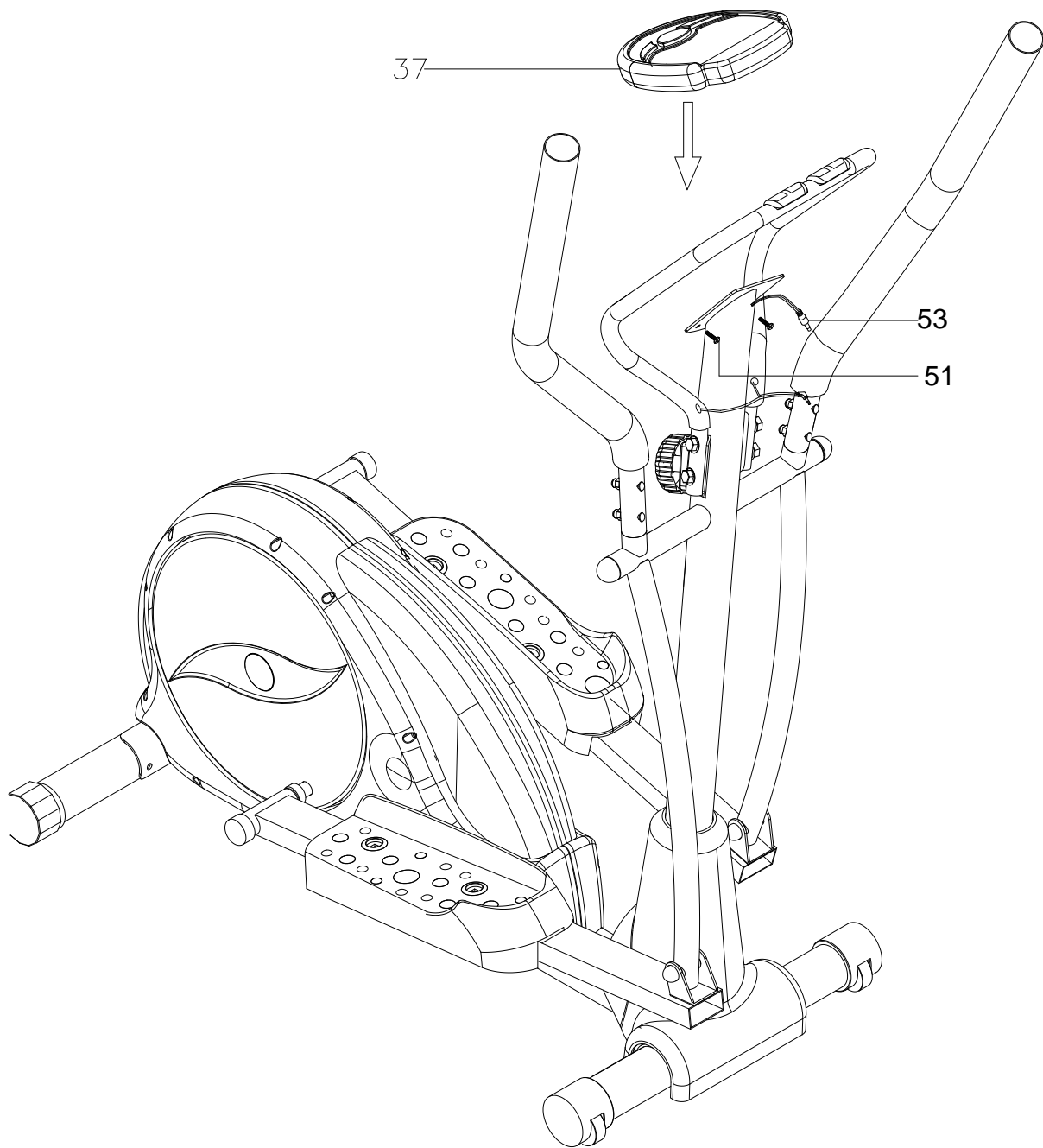

### ***STEP 8***

1. Mount the computer to the hold of the handlebar pole with the enclosed screws and connect the computer cables.
2. Plug the delivered hand-pulse wire for measuring the pulse rate in the socket at the computer.

# WARM-UP EXERCISE



15 seconds for each



20 seconds

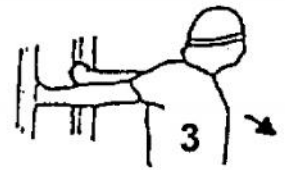

20 seconds

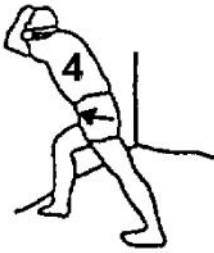

25 seconds



20 seconds



20 seconds



30 seconds



25 seconds for each leg



30 seconds

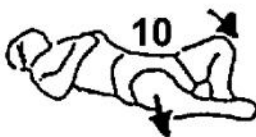

20 seconds



5 seconds x 3 times



20 seconds



20 seconds for each leg



5 times

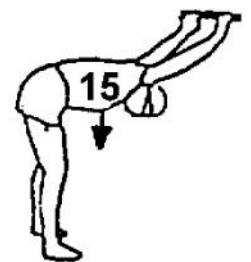

15 seconds

# EXERCISE COMPUTER

ST-6716-7



## FUNCTION BUTTON

- MODE** 1.PRESS “MODE” TO SELECT EACH FUNCTION DISPLAY ON THE MAIN SCREEN AND THE SAME ONE BLINKING ON THE BOTTOM FIELD.  
2.PRESS “MODE” AND HOLD ON FOR 2 SECONDS TO RESET ALL FUNCTION FIGURES.
- SET** TO SET FUNCTION OF TIME, DISTANCE, CALORIE, PULSE.
- RECOVERY** PRESS THE BOTTON TO HAVE RECOVERY FUNCTION WORK AFTER EXERCISING FOR A WHILE.

## FUNCTIONS

- SCAN** AUTOMATICALLY SCAN THROUGH EACH MODE IN SEQUENCE EVERY 6 SECONDS. THE DISPLAY LOOP IS SCAN-SPEED-RPM-TIME-DISTANCE-CALORIE-PULSE-SCAN ON THE MAIN SCREEN.
- SPEED** DISPLAYS CURRENT TRAINING SPEED, THE MAXIMUM IS 99.9KM/ML SPEED AND RPM WILL SWITCH DISPLAY TO ANOTHER EVERY 6 SECONDS.
- TIME** ACCUMULATES TOTAL WORKING TIME FROM 00:00 UP TO 99:59. YOU MAY ALSO PRESET THE TARGET TIME BEFORE TRAINING BY PRESSING “UP” AND “DOWN” BUTTONS. EACH SETTING IS 1:00 MINUTE. AS SOON AS THE TARGET TIME IS REACHED, TIME STARTS TO COUNT UP IMMEDIATELY AND ALARM FOR 8 SECONDS.

**DISTANCE** ACCUMULATES THE TRAINING DISTANCE FROM 0.00 TO THE MAXIMUM 99.90KM/ML WITH EACH INCREMENT 0.01KM/ML. YOU MAY ALSO PRESET THE TARGET DISTANCE BEFORE TRAINING BY PRESSING “UP” AND “DOWN” BUTTONS. EACH SETTING IS 0.5KM/ML. AS SOON AS THE TARGET DISTANCE IS REACHED, DISTANCE STARTS COUNTING UP IMMEDIATELY AND ALARM FOR 8 SECONDS.

**CARLOIRE** ACCUMULATES CALORIES CONSUMPTION DURING TRAINING FROM 0 TO THE MAXIMUM 9999 CAL WITH EACH INCREMENT 1 CAL. YOU MAY ALSO PRESET THE TARGET CALORIE BEFORE TRAINING BY IS REACHED, CALORIE STARTS COUNTING UP IMMEDIATELY AND ALARM FOR 8 SECONDS. (THIS DATA IS A ROUGH GUIDE FOR COMPARISON OF DIFFERENT EXERCISE SESSIONS WHICH CAN NOT BE USED IN MEDICAL TREATMENT.)

**PULSE** THE MONITOR WILL DISPLAY THE USER’S HEART RATE WHILE EXERCISING.

***GRIPPED SENSOR PULSE FUNCTION DESCRIPTION:***

YOU WILL SEE YOUR CURRENT HEART RATE (BPM) DISPLAY ON THE LCD DURING EXERCISING. WHEN YOU START TO EXERCISE, YOU HAVE TO HOLD ON GRIPS WITH BOTH HANDS, AFTER 30 SECONDS TO MAX. 1 MINUTE, THE PULSE FIGURE WILL DISPLAY ON THE LCD. IF YOU HOLD ON THE GRIP WITH ONLY ONE HAND, THE PULSE FIGURE DISPLAY WILL BECOME UNSTABLE. FOR THE PULSE FIGURE ACCURACY REASON, WE’LL SUGGEST YOU TO HOLD ON BOTH HANDS DURING EXERCISING.

**RECOVERY** AFTER EXERCISING FOR A PERIOD OF TIME, KEEP HOLDING ON GRIPS AND PRESS “RECOVERY” BUTTON, THE COMPUTER WILL STOP ALL THE FUNCTION DISPLAY EXCEPT “TIME” WHICH WILL BE COUNTING FROM 00:60 - 00:59 - 00:58 - .DOWN TO 00:00. AS SOON AS 00:00 IS REACHED, THE BOTTOM AREA OF LCD WILL SHOW YOUR HEART RATE STATUS WITH GRADE F1, F2, TO F6. F1 IS THE REST, AND F6 IS THE WORST. THE USER MAY KEEP EXERCISING TO IMPROVE THE HEART RATE STATUS (RECOVERY RESULT) DAY BY DAY FROM F6 UP TO F1.

**NOTE**

1. WITHOUT ANY SIGNAL BEEN TRANSMITTED INTO THE MONITOR FOR 4 MINUTES, THE LCD DISPLAY WILL SHUT OFF AUTOMATICALLY, AND ALL FUNCTION VALUES WILL BE KEPT. YOU MAY PRESS MODE OR START PEDALLING TO HAVE THE COMPUTER POWER ON AGAIN.
2. IF IMPROPER DISPLAY ON MONITOR, PLEASE RE-INSTALL THE BATTERIES TO HAVE A GOOD RESULT.
3. BATTERY SPEC: 1.5V UM-3 OR AA (2PCS).